



EVERPURE



SOLARIA APPLIANCE FOR INSTANT HOT WATER

Get luxurious instant hot water at the tap with the Everpure[®] Solaria[®] Instant Hot Water Appliance. The perfect complement to an Everpure commercial grade water filtration system, the Solaria delivers great tasting, piping hot water on demand. This unit offers a generous capacity of up to 100 cups of water per hour at 190°F. The Solaria is a compact unit that provides instant hot water from your tap for coffee, tea, hot chocolate, oatmeal, pasta, soups and much more.

FEATURES

- Dispenses piping hot water on demand
- Compact unit is easy to hide in any kitchen cabinet or wet bar
- Powder coated, insulated stainless steel tank is energy efficient and maintenance free
- Easy-to-install with quick connect fittings and drain plug



- Fingertip temperature adjustment
- Automatic shut-off which prevents accidental dry starts and prevents misuse
- Non-pressurized tank with self contained expansion chamber

SPECIFICATIONS

- **Dimensions**
6.8W x 11.2H x 8.1D in
- **Capacity**
100 cups per hour
- **Tank volume**
5/8 gallon
- **Temperature output**
140° F - 190° F
- **Inlet/outlet**
3/8" Outer dimension tubes
- **Power**
1300 watts
- **Motor compressor**
120 volts, 60 Hz

ORDERING INFORMATION

MODEL	PART NO	DESCRIPTION
Solaria	EV931840	Hot water appliance

GENERAL INSTALLATION / OPERATION / MAINTENANCE REQUIREMENTS

Not recommended for use with a Reverse Osmosis (RO) water filtration system – eventual damage to the pump will result. To prevent damage, install with a booster pump or autoclave.

Install the appliance away from heat sources and direct sunlight.

Do not install the appliance outdoors or in damp locations.

Minimum installation space – 2.5 inches from adjacent surfaces for proper air circulation around appliance.

The appliance generates heat, so external venting may be required when it is installed in a cabinet.

DRINKING WATER FAUCETS

Faucet and filtration system sold separately. Vented faucet required.

DIMENSIONS

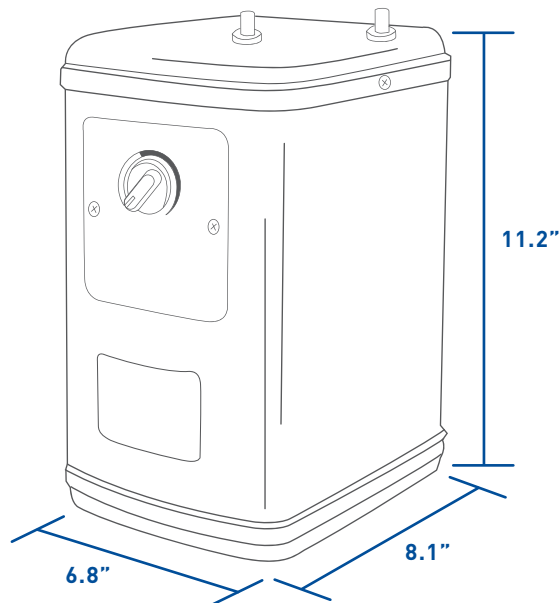

This water appliance is approved by Underwriters Laboratories Inc. in accordance with NSF/ANSI 61-2002e.



13845 BISHOPS DR., SUITE 200, BROOKFIELD, WI 53005 USA
P: 262.238.4400 | WWW.EVERPURE.COM

CUSTOMER CARE: 800.279.9404 | tech-support@pentair.com
© 2018 Pentair Residential Filtration, LLC. All rights reserved.

§For a detailed list of where Pentair trademarks are registered, please visit waterpurification.pentair.com/brands.
Pentair trademarks and logos are owned by Pentair plc or its affiliates. Third party registered and unregistered trademarks and logos are the property of their respective owners.

4002835 REV C MR18